

Wind Turbine Gearbox Test Stand

A wind turbine test stand capable of testing wind turbine speed-increasing gearboxes up to 2.5 MW at 2x rated load is being designed by Southwest Research Institute® (SwRI®). Design challenges include simulating the wind turbine rotor power being delivered to the gearbox at:

- Low speed (10–12 rpm)
- High torque (over 4 million ft-lbs)

To achieve the necessary power requirements, SwRI's design is based on an electrically regenerative test stand arrangement consisting of:

- Electric motor and variable frequency drive
- Generator
- Speed-reducing gearbox

This configuration allows for practical testing of the actual wind turbine drive train system with its own electrical generator and controller, or gearbox-only testing with a test stand generator and controller.

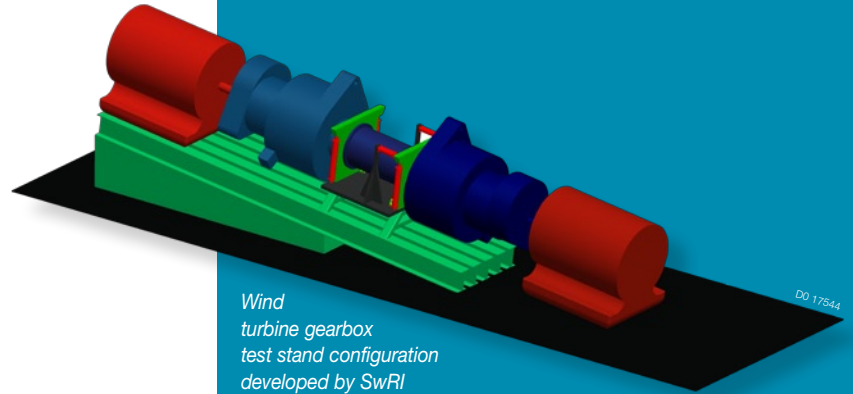

5-Degrees-of-Freedom Test Fixture

Through independent research, SwRI engineers discovered that most gearboxes fail in the field due to excessive bearing loads that are not adequately simulated by testing. In current testing practices, torque is the only load applied to the gearbox. Using SwRI's 5-degrees-of-freedom fixture, other forces (thrust, pitch, yaw, horizontal and vertical) can be added to the input shaft of the gearbox to better replicate the wind turbine rotor forces caused by wind fluctuations. This new testing methodology will allow gearbox and bearing manufacturers to test their products more accurately in a controlled test stand environment with a test duration of approximately 500–1,000 hours, at the harshest, realistic operating conditions. In actual wind turbine service, it would take 5–20+ years to encounter and accumulate these same loads.

Hardware-in-the-Loop Testing

SwRI has been an industry leader in the area of hardware-in-the-loop (HIL) testing and its application to high-horsepower electrically regenerative test stands used for gearbox testing. HIL testing takes real-world data and simulates it in a test stand environment. In applying HIL testing to wind turbines, SwRI can simulate wind forces with mathematical models sent to the motor and test fixture. HIL testing is also capable of simulating grid effects through power supply variation.

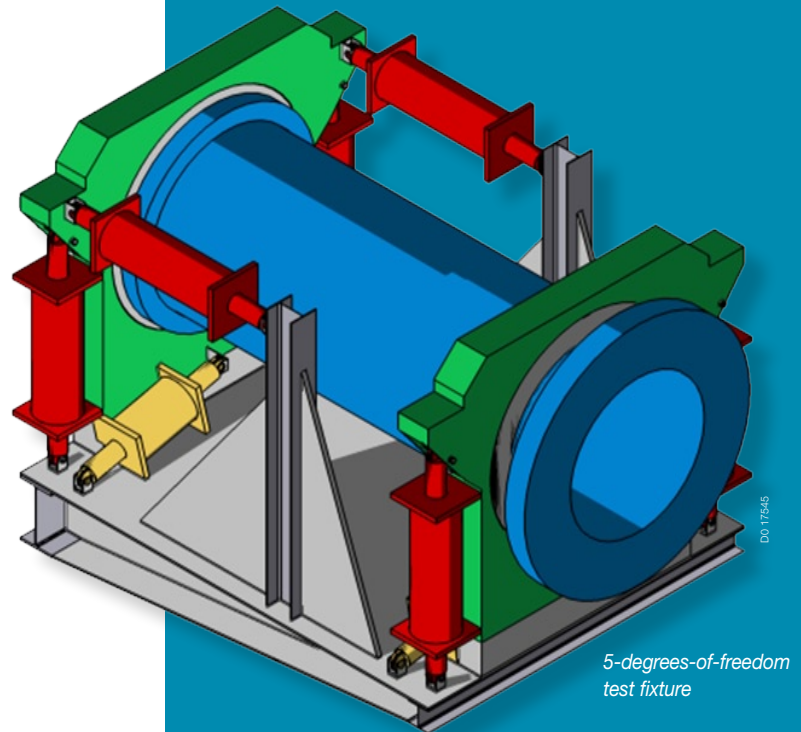

Quality Accomplishments

The Office of Automotive Engineering (OAE) at SwRI is certified to ISO 9001:2008, "Quality Management Systems – Requirements," accredited to ISO/IEC 17025:2005, "General Requirements for the Competence of Testing and Calibration Laboratories," and certified to ISO 14001:2004, "Environmental Management Systems." The OAE has also achieved Ford Tier 1 status for providing engineering services and the Engine, Emissions and Vehicle Research Division has received the Ford Q1 Quality Award. In addition, the Petroleum Products Research Department is a Nuclear Procurement Issues Committee (NUPIC)-approved laboratory and the Fuels and Lubricants Research Division has maintained its status as an American Chemistry Council (ACC)-approved laboratory.



Southwest Research Institute is an independent, nonprofit, applied engineering and physical sciences research and development organization using multidisciplinary approaches to problem solving. The Institute occupies 1,200 acres in San Antonio, Texas, and provides more than 2 million square feet of laboratories, test facilities, workshops and offices for more than 3,200 employees who perform contract work for industry and government clients.

We welcome your inquiries. For additional information, please contact:

Rebecca Winer

Engineer
(210) 522-6266
rebecca.winer@swri.org

Test Stand Development Fuels and Lubricants Research Division

Southwest Research Institute
6220 Culebra Road • P.O. Drawer 28510
San Antonio, Texas 78228-0510



*Benefiting government, industry
and the public through innovative
science and technology*

Equal Opportunity Employer M/F/D/V
Committed to Diversity in the Workplace

swri.org